

+D 1. 112:81-7

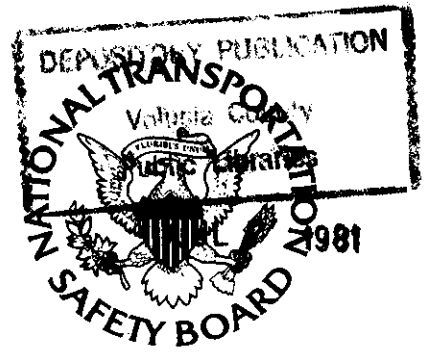

NATIONAL TRANSPORTATION SAFETY BOARD

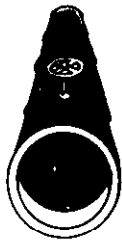
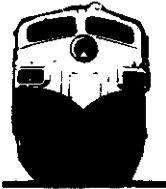

WASHINGTON, D.C. 20594

AIRCRAFT ACCIDENT REPORT

CONTINENTAL AIRLINES /
AIR MICRONESIA, INC.
BOEING 727-92C, N18479
YAP AIRPORT
YAP, WESTERN CAROLINE ISLANDS
NOVEMBER 21, 1980

NTSB-AAR-81-7

C. 3

*NTSB
AAR
81-7
C.3*

UNITED STATES GOVERNMENT

Doc
NTSB
AAR
81/07
c.5

TECHNICAL REPORT DOCUMENTATION PAGE

1. Report No. NTSB-AAR-81-7		2. Government Accession No. PB81-910407		3. Recipient's Catalog No.	
4. Title and Subtitle Continental Airlines/Air Micronesia, Inc., Boeing 727-92C, N18479, Yap Airport, Yap, Western Caroline Islands, November 21, 1980				5. Report Date Mar 27 1981	
7. Author(s)				6. Performing Organization Code	
9. Performing Organization Name and Address National Transportation Safety Board Bureau of Accident Investigation Washington, D.C. 20594				8. Performing Organization Report No.	
12. Sponsoring Agency Name and Address NATIONAL TRANSPORTATION SAFETY BOARD Washington, D. C. 20594				10. Work Unit No. 3261	
				11. Contract or Grant No.	
				13. Type of Report and Period Covered Aircraft Accident Report November 21, 1980	
				14. Sponsoring Agency Code	
15. Supplementary Notes The subject report was distributed to NTSB mailing lists: 1A, 8A and 8B.					
16. Abstract <p>At 0952 local time, on November 21, 1980, Continental Airlines/Air Micronesia, Inc., Flight 614, a Boeing 727-92C, N18479, crashed while attempting to land on runway 7 at Yap Airport, Yap, Western Caroline Islands. The aircraft touched down 13 feet short of the runway and the right main landing gear immediately separated from the aircraft. The aircraft gradually veered off the runway and came to rest in the jungle about 1,700 feet beyond the initial touchdown. Fire erupted along the right side of the aircraft as it came to a stop. All 73 Occupants (67 passengers and 6 crewmembers) escaped before fire destroyed the aircraft. Three persons received serious injuries; the remainder received minor or no injuries.</p> <p>The National Transportation Safety Board determines that the probable cause of this accident was the captain's premature reduction of thrust in combination with flying a shallow approach slope angle to an improper touchdown aim point. These actions resulted in a high rate of descent and a touchdown on upward sloping terrain short of the runway threshold, which generated loads that exceeded the design strength and failed the right landing gear. Contributing to the accident were the captain's lack of recent experience in the B-727 aircraft and a transfer of his DC-10 aircraft landing habits and techniques to the operation of the B-727 aircraft.</p>					
17. Key Words undershoot; hard landing; overload of main landing gear; improper touchdown aim point; dragged-in, flat approach; nonadherence to procedures; recency of experience; premature power reduction; habit pattern transfer; postcrash fire; emergency evacuation				18. Distribution Statement This document is available to the public through the National Technical Information Service, Springfield, Virginia 22161 (Always refer to number listed in item 2)	
19. Security classification (of this report) UNCLASSIFIED		20. Security Classification (of this page) UNCLASSIFIED		21. No. of Pages 47	22. Price

CONTENTS

	SYNOPSIS	1
1.	FACTUAL INFORMATION	1
1.1	History of the Flight	1
1.2	Injuries to Persons	3
1.3	Damage to Aircraft	3
1.4	Other Damage	3
1.5	Personnel Information	3
1.6	Aircraft Information	4
1.7	Meteorological Information	4
1.8	Aids to Navigation	6
1.9	Communications	6
1.10	Aerodrome Information	6
1.11	Flight Recorders	8
1.12	Wreckage and Impact Information	9
1.13	Medical and Pathological Information	10
1.14	Fire	10
1.14.1	Initiation and Propagation	10
1.14.2	Crash/Fire/Rescue	11
1.15	Survival Aspects	11
1.15.1	Restraint Systems	11
1.15.2	Evacuation	12
1.16	Tests and Research	13
1.17	Additional Information	13
1.17.1	Landing Gear Failure Analysis	1.3
1.17.2	Continental/Alt Micronesia Landing Procedures	14
1.17.3	Emergency Evacuation Training	18
1.17.4	Captain's Training	18
1.17.5	Continental Airlines "Sterile Cockpit" Policy	19
2.	ANALYSIS	19
2.1	The Accident	19
2.2	Training Aspects	21
2.3	Visual Illusions and Distractions	22
2.4	Survival Aspects	23
3.	CONCLUSIONS	24
3.1	Findings	24
3.2	Probable Cause	25
4.	SAFETY RECOMMENDATIONS	25
5.	APPENDIXES	27
	Appendix A--Investigation and Hearing	27
	Appendix B--Personnel Information	28
	Appendix C--Aircraft Information	32
	Appendix D--Runway Information	35
	Appendix E--Flight Data Recorder Traces	36
	Appendix F--Cockpit Voice Recorder Transcript	37
	Appendix G--Wreckage Distribution Chart	47

NATIONAL TRANSPORTATION SAFETY BOARD
WASHINGTON, D.C. 20594

AIRCRAFT ACCIDENT REPORT

Adopted: May 27, 1981

CONTINENTAL AIRLINES/AIR MICRONESIA INC.
BOEING 727-92C, N18479
YAP AIRPORT
YAP, WESTERN CAROLINE ISLANDS
NOVEMBER 21, 1980

SYNOPSIS

At 0952 local time, on November 21, 1980, Continental Airlines/Air Micronesia, Inc., Flight 614, a Boeing 727-92C, N18479, crashed while attempting to land on runway 7 at Yap Airport, Yap, Western Caroline Islands. The aircraft touched down 13 feet short of the runway and the right main landing gear immediately separated from the aircraft. The aircraft gradually veered off the runway and came to rest in the jungle about 1,700 feet beyond the initial touchdown. Fire erupted along the right side of the aircraft as it came to a stop. All 73 occupants (67 passengers and 6 crewmembers) escaped before fire destroyed the aircraft. Three persons received serious injuries; the remainder received minor or no injuries.

The National Transportation Safety Board determines that the probable cause of this accident was the captain's premature reduction of thrust in combination with flying a shallow approach slope angle to an improper touchdown aim point. These actions resulted in a high rate of descent and a touchdown on upward sloping terrain short of the runway threshold, which generated loads that exceeded the design strength and failed the right landing gear. Contributing to the accident were the captain's lack of recent experience in the B-727 aircraft and a transfer of his DC-10 aircraft landing habits and techniques to the operation of the B-727 aircraft.

1. FACTUAL INFORMATION

1.1 History of the Flight

On November 21, 1980, Continental Airlines/Air Micronesia, Inc., Flight 614, a Boeing 727-92C, N18479, was a regularly scheduled trip of passengers and cargo from Saipan to Palau with intermediate stops in Guam and Yap, Western Caroline Islands. 1/The crew began the day in Guam by flying N18479 as Flight 611 to Saipan, departing Guam about 0630. 2/ The captain made the landing at Saipan. Flight 614 departed Saipan about 0730 and landed at Guam about 0805. The first officer made the landing at Guam. The flight departed Guam about 0830. The en route phase at flight level 350 and the descent into the Yap area were uneventful.

1/ Yap is part of the U.S. Trust Territory of the Pacific Islands, specifically within the Western Caroline Islands group, about 450 miles southwest of Guam.

2/ All times contained herein are local time within one time zone at Greenwich mean time (GMT) plus 9 hours. The time of the accident was 2352 GMT, November 20, 1980.

At 0938:40, Flight 614 reported in range with Yap radio and received the local weather as follows:

2,000 ft scattered, estimated 30,000 ft broken, visibility 12 miles, temperature 84° F, dew point 78° F, wind 070° at 5 kns, altimeter 29.85 inches Hg., remarks: cumulonimbus east and southeast, towering cumulus north, rain showers east.

An en route descent to Yap was made from the north through broken to scattered clouds and the captain, who was flying the aircraft, turned onto a downwind leg at the northeast portion of the airport. The downwind leg was flown at an altitude of 600 feet above the runway 7 elevation while the crew checked to see if the runway was clear, to see if the firetruck was in place, and to see the direction of the windsock. The flaps were set at 30° on the base leg. Abeam the approach end of runway 7, the captain began a right 90° and a left 270° turn maneuver to align the aircraft with the final approach to runway 7.

During a portion of the downwind leg, the captain relinquished control of the aircraft to the first officer while the captain took pictures of the airport. He then resumed control and passed the camera to the second officer and asked him to take pictures of the runway. A short conversation followed regarding the operation of the camera.

As the aircraft passed through 90° from the runway heading, it had descended to about 300 feet above the runway elevation of 52 feet mean sea level (m.s.l.). When the aircraft was aligned with the runway heading, it was about 180 feet above runway elevation at a point 1.5 miles from the approach end of the runway. As the aircraft was completing the turn to final at 0951:18, the first officer said, "okay, two hundred fifty feet, sink five hundred." Six seconds later, the first officer said "tad low." The captain increased thrust and raised the aircraft nose slightly to reduce the descent rate. At 0951:30, the first officer said, "we're at one hundred and sixty feet," and 4 seconds later he said, "sink of three hundred." At 0951:45, the first officer said, "there's a hundred and twenty feet" and at 0951:55, he said, "fifty feet." Four to five seconds ^{3/} later, the aircraft touched down 13 feet short of runway 7. The right main landing gear immediately separated from the aircraft. The aircraft gradually veered off the runway and came to rest in the jungle about 1,700 feet beyond the initial touchdown.

A severe ground fire erupted immediately along the right side of the aircraft as it came to rest. Seventy-one occupants escaped through the two left overwing exits. Two crewmembers exited through the first officer's cockpit sliding window. All occupants had evacuated within about 1 minute after the aircraft came to rest. The aircraft was virtually destroyed in the postcrash fire.

The accident occurred during the hours of daylight at latitude 09°28'56" N, longitude 138°04'35" E.

During a postaccident interview, the first and second officers and a company mechanic who occupied the jumpseat stated that they felt the final approach path was low. The second officer and mechanic stated that they were just about to say something

3/ The time elapsed from the "fifty feet" callout is 4 seconds from the end of the callout and 5 seconds from the beginning of the callout.

to the captain when the first officer said "tad low." They said that after the captain increased thrust and reduced the descent rate, they felt the landing would be alright, although they felt it would be near the runway threshold. Then, according to these crewmembers, the captain retarded the throttles immediately after the "fifty feet" callout. The crewmembers said they were surprised when the captain reduced the throttles to idle. They said the rate of descent increased rapidly and the aircraft landed "hard." The first officer stated, "If the power had stayed on, I think we would have made the runway. . . maybe 500 feet down the runway." The captain stated during a postaccident interview that he was aiming for a touchdown point about 300 feet beyond the threshold. He said, "I believe I came across the threshold, I pulled the throttles closed and touchdown was like a pretty hard touchdown."

All of the crewmembers stated that the airspeed on the final approach was at or very near the "target" speed of 132 knots, which was the reference speed (Vref) for 30° flaps approach of 127 knots plus 5 knots. None of the crewmembers reported noting any destabilizing effects from wind during the approach; however, the first officer said he felt a slight destabilization of the aircraft as it passed over the trees shortly before impact. The captain reported that he noted a distortion of his view of the runway because of "heat waves" rising off the trees while on final approach. The mechanic stated that he believed the aircraft was about 25 feet above the treetops while on the final approach.

1.2 Injuries to Persons

<u>Injuries</u>	<u>Crew</u>	<u>Passengers</u>	<u>Others</u>	<u>Total</u>
Fatal	0	0	0	0
Serious	1	2	0	3
Minor/None	5	65	0	70
Total	6	67	0	73

1.3 Damage to Aircraft

The aircraft was destroyed by impact and postcrash fire.

1.4 Other Damage

A bamboo A-frame touchdown zone marker at the 1,000-foot point off the right side of the runway was destroyed by the right wing. A large area of jungle was destroyed by the aircraft passing through it and by the postcrash fire.

1.5 Personnel Information

The flightcrew had not flown together before the date of the accident. None of the crew had flown since November 1, 1980. The attempted landing at Yap was the first unsupervised landing at Yap for the captain. The captain, first officer, and second officer had recently changed flying positions, effective November 1, 1980, because of a reduction-in-force and reassignment of bids by Continental Airlines. The captain had previously been flying as a DC-10 captain based in Honolulu, Hawaii. The first officer had been flying as a B-727 captain in domestic operations. The second officer had been flying as a R-727 first officer in domestic operations. (See appendix B.)

The flightcrew had flown as passengers on a flight from Honolulu on November 20, 1980, the day before the accident, arriving at a hotel in Guam about 1700.

They were off duty about 12 hours before reporting for duty at 0530 on November 21, 1980. They flew about 2 hours 25 minutes prior to the accident and had been on duty about 4 hours 22 minutes at the time of the accident.

The captain, first officer, and second officer each had flown on duty into the Yap airport two times previously, at different and various times during September and October 1980. The captain and first officer each had made one landing at Yap with a check captain supervising before the accident.

A company mechanic was aboard to perform duties including refueling, and postflight, preflight, and other required maintenance as needed. His duties did not affect operational factors. He had been flying Air Micronesia routes for over 2 years and had ridden the jumpseat into Yap about 100 times.

16 Aircraft Information

The aircraft was certificated and maintained in accordance with Continental Airlines and Federal Aviation Administration (FAA) requirements. (See appendix C.) The center of gravity was within the prescribed limits for the approach and landing. The estimated landing weight at the time of the accident was 139,500 lbs, including 19,200 lbs of Jet-A fuel, according to the flightcrew. The maximum aircraft weight for landing at Yap was 138,300 lbs for a 3 flap setting with no headwind. The performance manual allows an additional 1,090 lbs for each knot of effective headwind when calculating landing weight limits. There was a 6-knot wind reported at the time of the accident.

A review of maintenance records revealed that all required inspections had been performed. A review of records from May 1980 to November 20, 1980, revealed no hard landing reported or hard landing inspections accomplished. The aircraft maintenance log sheet for November 21, 1980, was not recovered from the wreckage.

The aircraft was manufactured as a convertible cargo-passenger type. At the time of the accident it was configured for two pallets of cargo forward and 78 passenger seats in the aft cabin. (See figure 1.) As part of the certification for operation in the mixed configuration, the aft airstair door exit was a required emergency exit. A pneumatically actuated emergency "blow-down" system was required to be operational to provide positive opening of that exit with the aircraft in the most adverse exit opening condition that would result from the collapse of one or more of the landing gear. The system was reportedly operational for the flight.

17 Meteorological Information

Three surface observations made by the National Weather Service observer at Yap about the time of the accident were as follows:

0928--	2,000 ft scattered, estimated 30,000 ft broken, visibility 12 miles, temperature not available, wind 050 at 7 kns, altimeter 29.85 inches Hg, towering cumulus and rain showers east and south to southwest.
--------	--

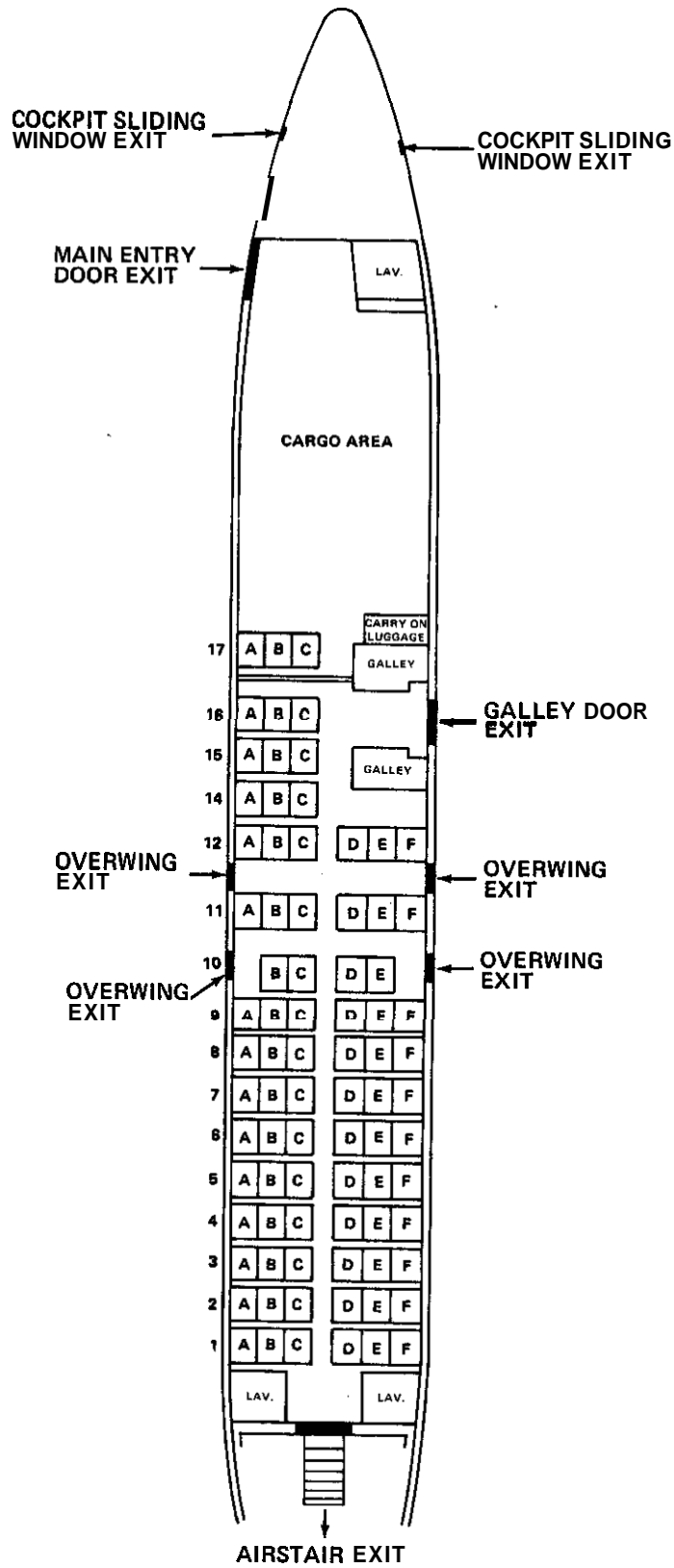

Figure 1.--Aircraft seating and exit locations.

- 0957-- 2,000 ft scattered, 13,000 ft scattered, estimated 30,000 ft broken, visibility 12 miles, temperature 84°, dew point 78°, wind 090' at 6 kns, altimeter 29.86 inches Hg, towering cumulus northeast, west and northwest, rain began at 0858 and rain ended at 0919.
- 1010-- 2,000 ft scattered, 5,000 ft scattered, estimated 30,000 ft broken, visibility 12 miles, wind 070° at 6 kns, altimeter 29.85 inches Hg, towering cumulus northwest to northeast.

1.8 Aids to Navigation

Yap has an approved nondirectional beacon approach procedure for runway 7. There was no visual approach slope indicator (VASI) installed on the runway.

19 Communications

There were no reported communications difficulties. Air-to-ground communications were conducted on 123.6 MHz (Unicom) at Yap.

1.10 Aerodrome Information

Yap Airport has one runway oriented 070°/250° magnetic. The runway is 4,820 feet long and about 100 feet wide. The runway base is composed of compacted coral with an asphalt-treated seal covering a width of about 75 feet. The seal coat had deteriorated in many places and there were rutted areas in the touchdown zone. The runway edges were not distinct because of grass which had grown through the surface along the edges. The approach end of runway 7 was not clearly defined, because the surface gradually sloped downward from the runway level. (see appendix D.)

The airport elevation is 52 feet m.s.l. The elevation of the approach end of runway 7 is 47 feet. The airport at Yap is not certificated by the FAA for air carrier operations because 14 CFR 139.3 exempts the Pacific Trust Territory airports from certification requirements. The airport does qualify for Airport Development Aid Program funds from the FAA. A new airport is under construction and is scheduled for completion in 1982.

There is no VASI or other glidepath guidance information available for the runway. There are 1,000-foot distance markers along each side of the runway and 6-foot-high white bamboo A-frame touchdown zone markers on each side of the runway 1,000 feet from each end of the runway. There are no runway end identifier markers or stripes on the runway. (see figure 2)

Continental/Air Micronesia operations specifications require crash/fire/rescue equipment to be available at the airport during takeoffs and landings. The equipment consists of one firetruck with a 500-gallon water capacity and a capability for a manual mix of aqueous film-forming foam (AFFF). The firetruck comes from a town about 20 minutes away and stands by at the airport during Air Micronesia's operations.



Figure 2.-- Approach to runway 7 at Yap Airport seen from one-half mile from the runway threshold.

1.11 Plight Recorders

A Fairchild model 5424 flight data recorder (FDR), serial No. 6061, was installed in N18479. The recorder was recovered from the wreckage and sent to the Safety Board's laboratory in Washington, D.C., for examination. The recorder sustained no impact or fire damage. The metal foil recording medium was examined, and all traces were found to have recorded in a clear and active manner with no evidence of malfunction.

The FDR traces for the final 8 minutes of the flight were read out (see appendix E). The altitude information was based on a barometric pressure of 29.86 inches Hg to convert pressure altitude to m.s.l.; no other corrections were made to the other parameters. The FDR airspeed trace showed a stabilized airspeed of about 132 knots during the final approach.

The FDR traces for the approach flown by the captain to Saipan earlier in the day were also examined and revealed that a low flat approach was flown there. The captain stated that he flew below the VASI glidepath to avoid clouds. He said that the final approach to Saipan was flown similar to the approach to Yap.

A Fairchild model A-100A cockpit voice recorder (CVR), serial No. 10065, was removed from the wreckage and sent to the Safety Board's laboratory for examination. The recorder was found in an area of severe fire damage. The CVR exterior and all unprotected electronic components were damaged by fire. There was no evidence of impact on the CVR case. The quality of the tape was excellent except for the innermost portion which had wrinkled edges as a result of heat transfer through the capstan. The last 13 minutes of the CVR tape were read out and transcribed (see appendix F).

The Safety Board's digital signal processing equipment was used to identify and document the frequency spectrum recorded by the CVR for the last position of the flight. A frequency was identified and documented that correlated to the sound identified by the CVR group as "engine pitch" noise. The frequency also matched the power change sequences recalled by the flightcrew during the final approach to Yap. The identified frequency fell within the 300-500 Hz range and was clearly present throughout the entire portion examined by the signal processor.

The "engine pitch" sound was stable, about 450 Hz, from the "okay, two hundred fifty feet, sink five hundred" callout at 0951:18 until the "tad low" callout at 0951:24. The frequency rose at that point to about 465 Hz. It remained at that level until about 1 second before the callout at 0951:55 of "fifty feet." Between that point and the sound of impact, the frequency dropped off rapidly from about 465 Hz to about 375 Hz. The dropoff of the frequency signal correlated directly to the reduced engine sounds recorded on the CVR at that time.

Previous investigations of the JT 8 model engine sound frequencies show that stage 1 and 2 fan blade passings are the dominant "noise." The stage 1 frequency levels expected during the final minutes of the accident flight would have ranged from 3,500 Hz to 5,000 Hz. Numerous unsuccessful attempts were made to isolate and document the frequency in the expected range. Production-noise engineers employed by the Boeing Company studied the spectral plots of the 400-Hz range frequency recorded on the CVR tape. They stated that the tone may be attributable to the "A" system hydraulic pump mounted on the No. 2 engine. They said that noise transmission to the flightdeck could be

expected to occur via the hydraulic line between the pump and the nose gear or via the No. 2 engine throttle cable. The hydraulic pump is driven directly from the N2 engine spool through a gear reduction of 0.292:1. According to Boeing, the relationship of the expected "ripple" frequency would be as follows:

$$f_{\text{ripple}} = \frac{N2(\%) \times 12245 \times .292 \times 9}{60}$$

Assuming N2 of 85 percent, the pump will generate a "ripple" pressure (frequency) of 456 Hz.

1.12 Wreckage and Impact Information

The first ground impact mark began 13 feet short of the runway threshold. (See appendix G.) This mark was made by the Nos. 3 and 4 tires on the right main landing gear. The left main landing gear tires touched down virtually on the threshold of the runway. A gouge made by the tail skid was found 2 feet short of the runway. Beginning about 100 feet beyond the threshold of the runway were several gouges and marks along the right side of the centerline made by the right wing inboard and outboard flap tracks. Heavy tire marks from the Nos. 1 and 2 tires began about 75 feet beyond the threshold of the runway and continued along the runway, gradually becoming lighter until the aircraft departed the runway surface. About 300 feet beyond the runway threshold, the left main gear tire marks and the scrapemarks from the right wing began a gradual turn to the right. The first evidence of nosewheel tire marks began about 600 feet beyond the threshold of the runway at the same point where the right wingtip began gouging the dirt and grass along the right edge of the runway. The left main tire marks departed the runway surface 1,000 feet from the runway threshold at the same time the right wingtip destroyed a bamboo A-frame touchdown zone marker located adjacent to the runway.

After the aircraft departed the runway surface, the right wingtip began digging into a 6- to 8-foot-high embankment about 1,150 feet from the runway threshold. The aircraft slid up over the embankment where the nose gear and left main gear assemblies broke loose. The right wing outer structure was destroyed by the embankment and fuel was spilled. The aircraft rotated to the right as it slid through dense jungle brush and it came to rest oriented 220° magnetic, about 1,700 feet from initial touchdown.

The right main landing gear assembly came to rest on the runway centerline about 1,260 feet from where the aircraft touched down. The No. 4 tire was found deflated, and a few pieces of rubber from the tread were missing. Two pieces of the tread were located along the left side of the runway about 100 to 200 feet from initial touchdown. The No. 3 tire remained inflated. The left main landing gear tires remained inflated during the accident. They showed evidence of scraping and gouging in an angular direction relative to the tread.

The right main landing gear drag strut fuse bolt (head portion) was found about 150 feet from initial touchdown. The left main landing gear drag strut fuse bolt was found near where the gear assembly came to rest. Both fuse bolts were retained for metallurgical analyses. Examination of both main landing gear assemblies revealed that the strut assemblies had separated from the attaching wing structure. The drag strut trunnion link attach clevis for each gear was spread apart and the fuse bolt was missing. All of the damage to the gear was found to be impact overload-type failures.

The entire fuselage was mostly consumed by fire from the aft pressure bulkhead forward. Only portions of the left side below the window line and belly area escaped severe melting and fire damage. The right side of the fuselage and the right wing structure were burned away **or** melted. The left wing was burned only on the top surface adjacent to the fuselage. It had sustained severe buckling and crushing. The cockpit interior, including the instrument panel, overhead, and pedestal, were consumed by fire.

The empennage escaped major fire damage. The aft pressure bulkhead door and airstair assemblies remained intact although damaged by fire. The airstair was found ajar with the aft portion down about 5 inches. The aft airstair emergency pneumatic extension system handle was found in the stowed position with the access cover in place. The pneumatic actuators were found charged and in the retract position.

The main entry, cockpit bulkhead, and galley doors were consumed by fire. The two left and two right overwing emergency window exits were consumed by fire. The upper portion of the upper deck cargo door was missing; the lower portion was damaged by fire.

The vertical and horizontal stabilizers were intact. The horizontal stabilizer jackscrew measured $3 \frac{7}{16}$ inches between the lower stop and traveling ballnut. This measurement corresponds to **10.7** units airplane noseup trim.

1.13 Medical and Pathological Information

A review of the flightcrew medical records revealed no ~~pre~~existing medical problems which would have affected their ability to conduct the flight safely.

The captain sustained fractures of the left collarbone and a bone in the top portion **of** his right foot. Both injuries resulted from the crash deceleration. One passenger sustained a fractured ankle and another sustained a fractured wrist. Both fractures occurred in the jungle **as** the passengers ran from the aircraft. The remainder of the injuries were minor bumps, bruises, and abrasions, most of which also occurred in the jungle. None of the occupants was burned.

1.14 Fire

1.14.1 Initiation and Propagation

The first evidence of fire and fuel spillage was about 300 feet before the area where the aircraft came to rest, at a point where the right wing and the fuselage first reached the top of the embankment adjacent to the runway. There were two scorched areas in the brush and grass which led to the main wreckage. The ignition source of the fire was not determined. Numerous sources of friction were present during the crash sequence, as well as electrical faults in the damaged right wing and hot metal surfaces caused by being rubbed on the runway surface.

According to eyewitnesses and aircraft occupants, fire was present along the right wing and fuselage area immediately after the aircraft came to rest. After the occupants evacuated, the fire spread to the cabin area through the open right overwing exit.

1.14.2 Crash/Fire/Rescue

The airport firefighter witnessed the accident from a distance of about 1,000 feet immediately across the runway from where the aircraft came to rest. After the aircraft came to rest, the firefighter manually poured 3 1/2 five-gallon containers of the AFFF firefighting agent into the 500-gallon watertank in the firetruck before proceeding to the aircraft. He estimated that it was 7 minutes before he was in position to apply the firefighting agent. The firefighter was the sole trained person on scene to fight the fire, although the mechanic aboard Flight 614 assisted him and gave instructions on where to apply the agent and water.

Direct access to the right wing area where the fire was concentrated was not possible because of a drainage ditch along the runway perimeter between the aircraft and the runway surface. The firefighter drove the firetruck down the runway a few hundred feet and then up a dirt road in the jungle to the area of the aircraft empennage. Because all of the occupants had evacuated by the time the firetruck reached the scene, firefighting efforts were concentrated on the area of the CVR and FDR (aft fuselage) and the cockpit to reduce the fire damage. The truck-mounted turret was not used to apply the agent. A 1 1/2-inch handline was used to direct the agent. The firefighter departed the scene six times to refill the firetruck with water. Three and one-half 5-gallon containers of AFFF agent were added to the second load of water; the remaining loads of water were applied directly. The firefighter stopped at 1800 after using 3,500 gallons of water and 35 gallons of AFFF agent. Each round-trip to secure water required about 20 minutes. On one trip to town to refill, the firetruck fuel pump malfunctioned and the mechanic who had been aboard Flight 614 went and assisted the firefighter in repairing the truck.

1.15 survival Aspects

1.15.1 Restraint Systems

The captain, first officer, and second officer had fastened their seatbelts and shoulder harnesses. They reported no failures of their restraint systems, although none could recall whether the inertial reels locked for the shoulder harnesses during the accident. The mechanic was wearing only his seatbelt; he reported no problems with his seat or seatbelt. No cockpit occupant reported any seat security problems except for the first officer who stated that the right armrest initially blocked the opening of his sliding window when he attempted to open it.

Although none of the passengers or cockpit crewmembers reported any cabin seat failures, the mechanic reported that he noticed two seats in the aft left cabin area and one seat on the right forward area were "uprooted" from their normal positions. According to a passenger seated at seat 16A, ^{4/} a passenger in seat 16B unfastened her seatbelt and stood up as the aircraft was sliding on the runway. Another passenger in seat 2F said that a passenger in seat 2D unfastened her seatbelt and stood up while the aircraft was skidding. The passenger in seat 2F tried to restrain her, so he unfastened his seatbelt, grabbed her, and held her to the floor. They both remained on the floor until the aircraft came to rest. None of these unrestrained passengers was injured.

^{4/} Seat row numbers began at one (1) and ran forward from the back of the cabin.

1.15.2 Evacuation

The first officer attempted to open his sliding window but was unable to do so. He then crawled over the cargo area and entered the passenger cabin to assist in the evacuation. He later exited via a left overwing emergency window. The captain attempted to open his sliding cockpit window but it would not move. He said the handle rotated but nothing else moved. He eventually opened the first officer's sliding window after moving the first officer's seatback. He also assisted the mechanic in an attempt to open the forward entry door (left side). The door was "popped" slightly open but it was jammed and could not be forced open. The second officer crawled over the cargo and also exited through a left overwing emergency window. The mechanic attempted to open the forward entry door, then crawled over the cargo to the cabin. He returned to the cockpit because the last passengers had left the cabin. Then he and the captain exited the cockpit via the first officer's window. The first and second officers and the mechanic reported that all passengers had departed from the cabin by the time they reached it. The cockpit occupants reported that the cargo remained in its restraining nets but shifted and appeared "flattened out," blocking the aisleway along the left side of the cargo area.

The flight attendant seated on the left aft entry door jumpseat stated that she shouted "grab your ankles—keep your head down" as the aircraft slid after what she described as an "extra hard landing." She said some oxygen masks on the right side of the cabin fell down at touchdown and the cove light covers on the right side fell on passengers during the ground slide. Other items fell from the overhead racks. She said her jumpseat remained normal and her seatbelt and harness functioned normally.

After the aircraft came to rest, she attempted to open the aft pressure bulkhead door leading to the aft airstair exit. She said two passengers interfered with the opening of the door because it opens inward. When she got the door open, she attempted to open the airstair with the normal handle, but it did not operate. She did not attempt to use the emergency extension handle for the pneumatic system because she was not aware of the system. She stated that the cabin began to fill with smoke so she shouted at the passengers attempting to use the aft airstair exit telling them to go forward. She used empty Dillowcase covers to cover her mouth and nose, as the smoke was "thick, acrid and suffocating." She noticed light coming from the forward part of the cabin and screamed for the passengers to turn and go forward. She went forward in a crouched position and exited via the aft left overwing exit. Once outside, she had difficulty in keeping the passengers moving away from the aircraft.

The flight attendant seated in seat 16C, opposite the galley door, said the landing forces were "very severe." He saw the emergency exit light (flashlight type) over the galley service door fall to the floor along with the public address microphone and the service phone. Also, the coffee pots fell out of the coffee makers.

When the aircraft came to a stop, he unfastened his seatbelt and yelled for the passengers to unfasten their seatbelts. He went to the galley door (right side) and observed flames outside. He turned and noticed that the left overwing exits were open and the right forward overwing exit was open and flames and smoke were entering the cabin. He went to the cargo compartment to obtain the dry chemical fire extinguisher and to check the forward door. He returned to the cabin and fought the fire around the forward right overwing exit until passengers had evacuated. He then left the aircraft through the left forward overwing exit. The flight attendant stated that he routinely timed the landing roll by pushing his stopwatch at touchdown. In this case, he was

startled by the hard landing, but he started his watch when the aircraft came to a stop. After he exited the aircraft, he looked back as the last two passengers and the other flight attendant exited, and he pressed his stopwatch again. He said the timer showed 54.48 seconds. He said the second officer exited the aircraft at this time and was the last person to exit the aircraft. He said the aft portion of the fuselage was obscured by smoke at that time.

1.16 Tests and Research

The left and right main landing gear strut bolts, part number (P/N) 65C18879-3, were examined at the Safety Board's and the Boeing Aircraft Company's metallurgy laboratories. The examinations revealed that the bolts sheared transversely about 2 1/2 inches from the bolt head. The fracture locations occurred along a circumferential groove machined in the inside diameter of the bolts.

The fractures on each bolt displayed deformation and features indicative of direct shear overload. There was no evidence of preexisting fatigue cracking. Hardness measurements on both bolts were between 46 and 48 Rockwell "C," within the specified design strength for the bolts. A spectrochemical analysis of the bolts revealed that the steel contained the proper chemical makeup and the microstructure appeared normal for the heat treatment required.

1.17 Additional Information

1.17.1 Landing Gear Failure Analysis

The failure of the right main landing gear was evaluated to determine if the impact forces exceeded the design strength of the gear assembly. The forces which imparted the shear force to the right gear strut fuse bolt were generated by two conditions: (1) the horizontal speed (ground speed) of the landing gear when it struck the upward sloping terrain, and (2) the rate of descent (vertical speed) of the landing gear at the time of touchdown. Both of these factors would have generated loads through the landing gear structure to the fuse bolts.

According to data supplied by Boeing, a tension load of 296,500 lbs acting on the drag strut would have sheared the fuse bolt, P/N 65C18879-3. The various main landing gear geometric angles and moments were studied and it was calculated that a vertical speed of 1,321 feet per minute (ft/min) for the accident aircraft would have produced a 296,500-lb load at the fuse bolt. The 1,321 ft/min vertical speed component would have resulted from the combination of the aircraft's actual vertical flightpath descent rate and the effective vertical speed component imparted to the landing gear by the aircraft's horizontal speed and the upward sloping terrain at touchdown.

The area where the right main landing gear first contacted the ground and moved over the ground for about 13.08 feet had an upward slope of 4.07°. The terrain from the initial point of contact to a point 5.4 feet beyond the beginning of the paved area had an average slope of 4.97°. The 4.07° upslope figure was used for calculations because it was the most conservative figure and because the marks in the ground showed that the right main landing gear had separated before reaching or traversing the slightly steeper surface.

The aircraft's horizontal speed of 121 knots at the initial touchdown as derived from the FDR, less a headwind factor of 6.6 knots produced by the reported wind, 050° at 7 knots, indicates that the aircraft's horizontal speed (ground speed) at impact was 114.4 knots (193ft/sec). That horizontal speed in relation to the 4.07° slope provided a 824 ft/min (13.74 ft/sec) effective vertical speed at touchdown which was imparted to the aircraft because of the upslope.

The total vertical speed to fail the landing gear strut fuse bolt (1,321 ft/min or 22.0 ft/sec) minus the speed induced by the upslope (824ft/min or 13.74 ft/sec) leaves a vertical speed of 498 ft/min (8.3 ft/sec). Therefore, a vertical speed of 498 ft/min or more would have produced loads exceeding the design strength of the fuse bolt on the accident aircraft.

The aircraft's vertical speed during the final phase of flight could not be derived directly from FDR data because of ground proximity effects on the altitude traces. Ground effect is generally considered to be at altitudes less than one-half the aircraft's wing span--in this case about 54 feet above ground level (AGL). The altitude data and groundtrack trace (see appendix E) show that Flight 614 entered ground effect about 0.5 mile from the runway threshold. The terrain and treetops rise rapidly about 0.6 mile from the runway threshold at the edge of the sea and are actually higher than the runway elevation along part of the flightpath. The first officer's callout at 09:51:30 of "we're at one hundred and sixty feet" at about 1.1 mile from the runway and the callout at 09:51:45 of "there's a hundred and twenty feet" about 0.6 mile from the runway correlate directly with the FDR altitudes at those points on the groundtrack altitude trace. However, all FDR altitude data after that point are influenced by ground effect.

Based on the first officer's callout, FDR altitudes, and elapsed time from the CVR, the average rate of descent from 1.2 mile to 0.6 mile from the runway was calculated to be 160 ft/min. If the rate of descent from 0.6 mile out to impact had been linear, the average rate of descent would have been 320 ft/min. However, the first officer called "50 feet" about 4 to 5 seconds before impact. That callout referred to 50 feet above the runway elevation, according to the first officer. Assuming the first officer was correct and the aircraft was 50 feet above the runway touchdown zone at that point, the descent rate from 0.6 mile out to the 50-foot point would have been about 120 ft/min. This rate of descent correlates with the cockpit occupants' statements that the captain added power and decreased the rate of descent following the copilot's "tad low" callout at 0951:24. To account for the total altitude lost, and considering the relatively low descent rate to the point of the "50 feet" callout, it was apparent that the descent rate increased rapidly after the 50-foot callout. If the aircraft was at 50 feet above the runway 4 or 5 seconds before impact, the average rate of descent would had to have been 750 ft/min or 600 ft/min, respectively.

1.17.2 Continental/Air Micronesia Landing Procedures

The Continental Airlines flight manual for the Boeing 727-100/100C graphically depicts the normal approach situation. (See figures 3 and 4.) Flap and landing gear extension points were selected to minimize crew workload and thrust changes during the approach. The flight manual states, in part, "The airplane must be stabilized on final approach at least 500 ft above field elevation." Following are excerpts from the flight manual regarding other landing procedures:

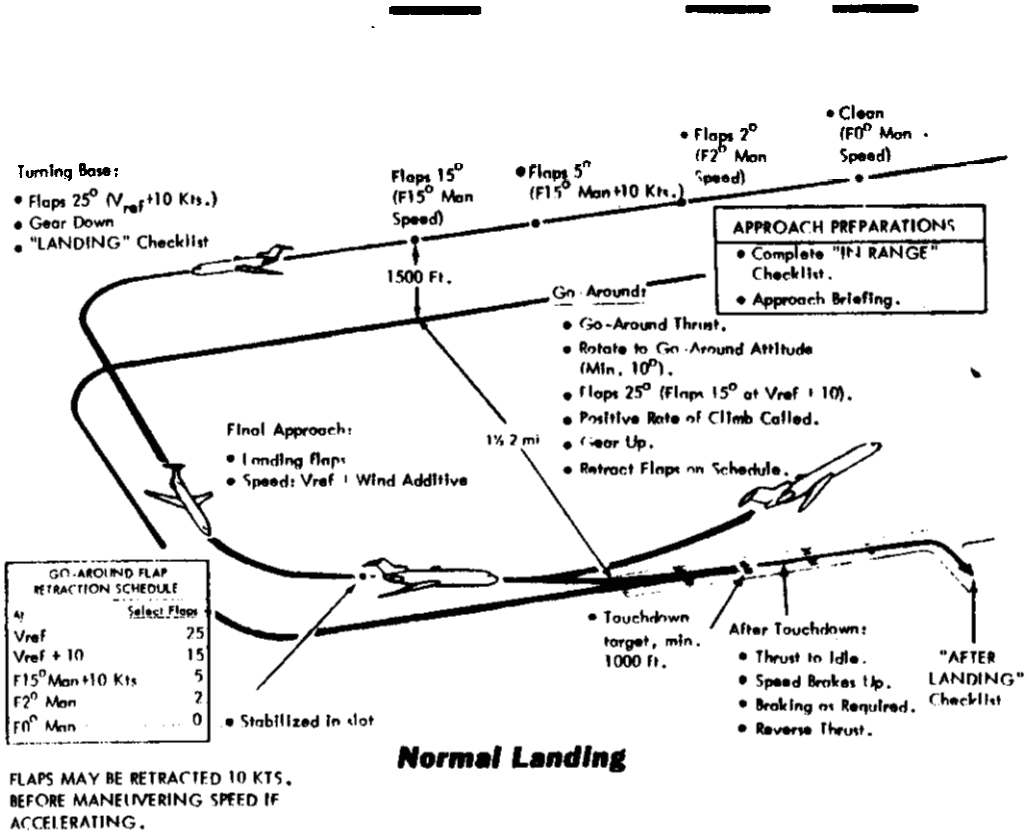
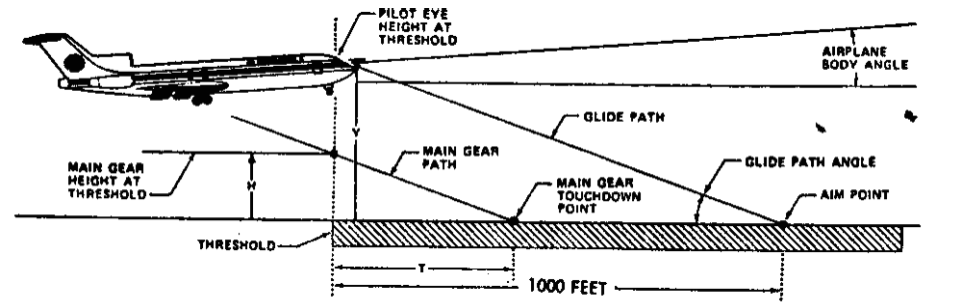

Figure 3.-- Depiction of normal landing from flight manual.



ESTIMATED TOUCHDOWN POINT (NO FLARE) ASSUMING A 1000 FT. AIM POINT
(SPEED - ON BUG, FLAPS - 30)



FLAPS	GLIDE PATH ANGLE (DEGREES)	ESTIMATED BODY ANGLE (DEGREES)	PILOT EYE HEIGHT, Y, AT THRESHOLD (FEET)	MAIN GEAR HEIGHT, H, AT THRESHOLD (FEET)	MAIN GEAR TOUCH-DOWN POINT, T (FEET)
30	2.0	1.8	34.92	10.95	313
30	25	4.3	43.M	19.20	440
30	2.75	4.0	48.03	23.31	485
30	3.0	3.8	52.41	27.40	523

NOTE: MAIN GEAR 60 FT. BEHIND AND 14 FT. 10 IN. BELOW PILOT IN LEVEL FLIGHT.

Estimated Visual Approach

Figure 4.--Depiction of estimated visual approach from flight manual.

FINAL APPROACH

- (a) Once landing flaps have been established, target speeds (under stable air conditions) will be $V_{REF} + 5$ knots. However, the decrease in wind velocity approaching the surface of the earth has the effect of a decrease in airplane velocity. Consequently, caution must be exercised to prevent airspeed bleed off and increased sink rate during the last stage of the approach.

Target approach speed is $V_{REF} + 5$ knots for landing in reported winds of zero to light and variable (up to 10 knots). When landing in higher wind conditions, add $1/2$ the steady headwind and the full value of the gust to V_{REF} . The total wind additives should not exceed $V_{REF} + 20$ knots.

- (b) The pilot should aim for a constant angle relationship with the 1,000 ft. mark on the runway, coordinating pitch attitude and power changes. As the end of the runway and then the 1,000 ft. mark disappear under the nose, maintain the stabilized attitude, around $2-3^\circ$ nose up, and power setting that have made good this constant angle until the 50 foot level is reached.
- (c) The pilot should restrain himself from the tendency to 'dive' at the runway when braking clear of the clouds at low altitudes under instrument conditions, ~~or~~ as the end of the runway disappears under the nose in visual flight conditions. The high rates of sink that develop with this maneuver are not readily apparent on either the airspeed indicator ~~or~~ the vertical speed indicator, and may not be noticed until the flare point at 50 feet.

Rapid rotation to stop a high sink rate is relatively ineffective since the induced "G" tends to offset the increase in lift. Thrust must be added to decrease a high sink holding the proper approach speed and using a normal rotation.

- (d) The desired visual final approach condition is airspeed at target ($V_{REF} +$ wind additive) and a 3° glide path that will result in main landing gear touchdown at 1,000 feet beyond the runway threshold. When the desired condition is established, maintain it to flare height. Do not "duck under" an established glide path near the runway threshold to achieve an early touchdown.

Flare and Landing

During a visual approach, the main landing gears should cross the runway threshold at 50 feet. Main touchdown will occur just beyond 1,000 feet, assuming the glide path angle is 3° . Do not deviate from the glide path in an attempt to touch down sooner.

Flare results in a change in attitude of only $2-3^\circ$. At light weights, the change is hardly noticeable.

As soon as the pilot observes response of the airplane to the flare, the throttles should be retarded smoothly to idle, and any back pressure on the control column relaxed.

Gravel Landing Operation

Prior to landing, the pilot not flying will brief the other crew members to:

- A) Raise flaps to **B** immediately after touchdown.
- B) Maintain engines #1 and #3 in reverse idle.

Reverse thrust, as outlined in the landing notes, will be applied only to engine #2. Engines #1 and #3 will be maintained in reverse idle, unless circumstances dictate otherwise.

The procedures for landing at Yap require the pilot to "fly-by" the airport on the downwind leg to check the runway. This procedure places the aircraft closer to the airport and at a lower altitude than a normal downwind leg.

1.17.3 Emergency Evacuation Training

Title 14 CFR 121.417, Crewmember Emergency Training, specifies, in part, "(b) Emergency training must provide the following: . . . (2) individual instruction in the location, function and operation of emergency equipment including - (i) Equipment used in ditching and evacuation; . . . (iv) Emergency exits in the emergency mode . . ., with training emphasis on the operation of the exits under adverse conditions." Paragraph (c) of that part requires that each crewmember must "actually operate" the emergency equipment, including exits, during initial and recurrent training.

The Continental/Air Micronesia flight attendant manual contained no description or procedures for the operation of the aft airstair emergency opening system. The pilot's flight manual did contain such information.

A few days after the accident at Yap, 11 newly-trained flight attendants arrived in Guam to begin duties in Air Micronesia operations. Interviews with those flight attendants revealed that none had received training in, nor were they aware of, the operation of the emergency opening system for the airstair. Continental/Air Micronesia management personnel participating in the investigation took immediate action to require thorough training of all flight attendants in the operation of the airstair before the attendants went on duty. The training program at Continental Airlines training facility was revised to include such instruction and the "hands on" training airstair mockup was redesigned to incorporate the emergency system.

1.17.4 Captain's Training

The assistant flight manager of Continental Airlines from Honolulu gave the captain of the accident aircraft his line training in Air Micronesia operations from September 13-21, 1980. The check captain stated that during training he stressed the use of 40° flaps, aiming for the 1,000-foot touchdown zone, using a 3° glideslope, and descending about 700 ft/min on the final approach. He said that the approach and landings at Yap' and Truk, another airport with a short runway (5,100 feet), produce adverse psychological factors in crews; however, hundreds of successful landings have

been made safely and the runway lengths at Yap and Truk are within the performance capabilities of aircraft that use the facilities.

The check captain stated that the captain made about 20 landings during his 8-day training itinerary, including one at Yap. (See appendix B.) He said that the captain also observed a landing at Yap. The check captain recalled that the approach and touchdown by the captain at Yap was good. He said that the captain "initially was rusty on 40° flap landings but subsequently improved."

Regarding the captain's statement during a postaccident interview that he had made the approach on November 21, 1981, to Saipan below the VASI glidepath to remain below clouds, the check captain and flight manager expressed concern. They said that the VASI glidepath should be maintained particularly during low-visibility, night-condition approaches.

Both flight managers stated that the 1,000-foot touchdown aiming point is taught for the B-727 and DC-10 aircraft, regardless of the runway length. No changes are made in landing procedures as far as pattern altitudes, glidepath, or touchdown aim points for short runways. This is to provide standardization and to maintain the safety margins for all approaches and landings.

The flight managers also stated that when a newly assigned captain begins Air Micronesia operations, they schedule a first officer with extensive experience in Air Micronesia operations to fly with the "new" captain the first few days. An experienced first officer had been scheduled to fly with the captain on Flight 614, but he called in sick. The next available first officer who was then assigned to the flight was also "new" to Air Micronesia operations. 

Both flight managers and other pilots involved in the investigation stated that the throttle technique used by the captain for the accident landing at Yap was more appropriate for DC-10 landings. They said normal technique for the DC-10 permits reduction of thrust to idle before touchdown without a resultant rapid descent. They said that reduction of thrust to idle at 50 feet in a B-727, especially on a flat approach path, causes a rapid descent which even large stabilizer inputs cannot overcome.

1.175 Continental Airlines "sterile Cockpit" Policy

Continental Airlines flight manual and checklist procedures (also applicable to Air Micronesia operations) include a "sterile cockpit" procedure. The following is contained in the flight manual for the "Before Takeoff" and "In Range" checklist: "NOTE: It is [Continental Airline] policy that below 10,000 feet only those conversations necessary for the safe operation of the flight will be carried on in the cockpit. It is recommended that the sterile cockpit light be turned on at 10,000 feet."

The "In Range" checklist contains the following: "Note: Captain will ascertain proper time to turn sterile cockpit light on."

2 ANALYSIS

21 The Accident

The investigation revealed that the flightcrew was properly certificated and qualified to conduct the flight. The aircraft was properly certificated, equipped, and

maintained. The landing gross weight was within limits for the reported winds and the 30° flap setting.

The overload condition imposed on the right landing gear was caused by two conditions: the upslope of the area where the touchdown was made and the descent rate of the aircraft at touchdown. The investigation revealed that the shear load imparted to the landing gear as a result of the upsloping terrain was **824 ft/min (13.74 ft/sec)**, which would have been below the design strength if the aircraft had been on a level runway. Similarly, the calculated vertical descent rate (600 to **750 ft/min**) would have imparted a shear load to the landing gear well below the design strength for a touchdown on a level runway. The combination of the two forces, however, exceeded the design strength of the gear. Also, the right main landing gear sustained the full force of the impact without the left main landing gear sharing the load of a simultaneous contact. Therefore, the combination of the upslope at the touchdown point and the vertical descent of the aircraft caused the right main landing gear to separate.

The Safety Board's analysis of the evidence in this accident focused on the reasons why the aircraft landed short of the runway. The investigation revealed no mechanical or meteorological reason which could have caused the short landing. Examination of the wreckage and a kinematic analysis of the dynamics of the touchdown revealed that the design strength of the right main landing gear structure was exceeded by the forces of the impact. The right main landing gear separated as designed, precluding worse damage to the wing and fuselage structure and preventing a serious fuel spill at impact. The events subsequent to the initial touchdown were incidental only to the survival aspects of the accident. ■ ◆

It is apparent from the statements of the four flightdeck occupants and from the CVR and FDR information that the landing pattern at Yap was flown low and flat, which was not the standard prescribed procedure. Nevertheless, **all** four flightdeck occupants believed that the aircraft was going to make a safe landing until the aircraft was about 50 feet above the runway and the captain reduced the thrust to idle. Although the first officer, second officer, and the mechanic were concerned about the final approach being low, they apparently believed the aircraft would land on the runway until the power was reduced. The captain stated that he still believed that the aircraft would land on the runway, although closer to the threshold than he had planned. Airspeed was maintained at or near reference speed until the point where power was reduced about **50 feet** above the runway. At that point, the descent rate increased rapidly when the thrust was reduced to idle. Even though the control yoke was probably pulled aft in an attempt to maintain the approach path, without power the airspeed decreased rapidly and the descent rate increased rapidly because the aircraft had insufficient thrust in relation to drag to reach the runway. Therefore, the aircraft landed short of the runway because the captain prematurely reduced the thrust.

There are several reasons why the captain arrived at a point in this approach where he mistakenly reduced thrust and landed short. Of these reasons, the one of major concern to the Safety Board was the manner in which the approach was flown. The Safety Board believes that the captain's failure to fly a standard, approved pattern directly contributed to the final outcome. It was apparent from the captain's statements that he was concerned about the short runway, and that he intended to touch down before the company-prescribed touchdown point of 1,000 feet. The captain's training in both **the DC-10 and B-727** aircraft and flight manual procedures emphasized the need to plan a pattern for a touchdown aim point of **1,000 feet** beyond the threshold of the runway. Admittedly, the length of the runway at Yap (**4,820 feet**) is comparatively short; however,

the stopping procedures and certification data for the aircraft insure a safe landing if recommended pattern procedures are followed. The Safety Board believes that the captain was ignoring these criteria and was concerned about the short length of the runway; therefore, he planned to land about 300 feet rather than 1,000 feet beyond the runway threshold.

The approach to Yap was not typical of the type previously flown by the captain. The fly-by procedure to check the runway placed the aircraft in an abnormal position on the downwind leg of the pattern. Once the fly-by was completed, however, the captain was required to establish a normal base leg and final approach. In this case, the captain did not regain the proper altitude for a normal base leg; instead he turned for the final approach about 1.5 miles from the runway at only 250 feet above the runway elevation instead of being stabilized on the final at 500 feet as recommended in the approved flight manual. If he had turned on the final approach at the same distance but at the proper altitude of 500 feet, he would have been on a normal 3° approach slope angle to the 1,000-foot aim point. However, the low base-leg altitude and turn to the final approach required a flat approach slope angle of about 1.5° and a low rate of descent. He probably flew the approach in this manner to attempt a short field-type landing. Because he failed to establish a proper glidepath, his sight picture of the runway, as compared to a standard pattern, would have been abnormal, and more thrust would have been required to hold the lower-than-normal descent rate. This type of dragged-in, flat approach places an aircraft in a difficult situation with respect to windshear, downdrafts, or loss of thrust. Because the margins for error are much less in this type of approach, the FAA and airline companies prescribe standard stabilized approach procedures for jet transport category aircraft.

A standard flight pattern procedure by the captain was all the more important in this case because this was his first unsupervised landing at Yap since he resumed flying a B-727 aircraft. His recent requalification in the B-727 and limited familiarity with Yap should have alerted him to use the prescribed procedures. If he had, he would have had a greater margin for error. If he had reduced the throttles to idle at 50 feet over the runway surface during a prescribed approach, a hard landing probably would have resulted, but it is not likely the aircraft would have been damaged. The transition to a landing attitude begun at 50 feet from a normal 3° approach slope angle and the prescribed smooth thrust reduction will generally result in a normal landing, whereas a dragged-in, flat approach requires excess power.

22 Training Aspects

The Safety Board believes that the captain's premature reduction of thrust on this final approach may have resulted from a habit pattern developed during his previous experience in landing the DC-10. Specifically, the DC-10 has mass/energy and aerodynamic characteristics which produce a greater tendency to float in ground effect than does the B-727. Further, the DC-10 does not necessarily require comparatively as much thrust carried until at or near touchdown as does the B-727. Thus, the captain's prior experience in landing the DC-10 could have contributed to the development of a thrust reduction habit pattern which, although appropriate to the DC-10, was not appropriate for the B-727, especially during a low, flat approach in the B-727. The captain certainly should have been aware of the aircraft differences from his training; however, he did have a long delay from his last B-727 training flight to his first line flight (61 days). He also returned to flying the DC-10 before his B-727 line flying. This training sequence and time factor does occur in routine airline operations, especially following a reduction-in-force or other schedule changes.

The procedures followed in this case meet all the Federal regulations and have not been shown to be improper in the past. Ideally, transition or requalification training should follow a pattern whereby the pilot goes from one aircraft model to training in another and directly into line flying in the second. Practically, this situation is not always possible because of airline operational and schedule requirements and has not been identified as a factor in past airline accidents. However, this situation must be considered to be a factor in this accident, because if the captain had flown a proper pattern, this accident might not have occurred.

The captain's statement that he had flown his training flights into Yap and Truk in a manner similar to the accident approach was not substantiated by the check captain. Moreover, examination of the FDR data for the captain's landing at Saipan on November 21, 1980, showed that he also flew a flat approach to that runway. He said he did so to remain clear of clouds, even though his final approach path was below the VASI glide slope.

The interview with the check captain who gave the captain his line qualification for Air Micronesia confirmed that a 3° glide slope with about a 700 ft/min rate of descent is taught, even for Yap and Truk. He stated that he stressed the 1,000-foot aim point with thrust maintained to touchdown. The check captain stated that deviating below the VASI glide slope is not condoned, especially to avoid clouds, because the VASI is the aid most necessary to insure a proper glidepath and to prevent a short landing. The Safety Board could not determine a reason for the captain to ignore the training and procedures established for such landings.

The company's unwritten practice of providing a first officer who was experienced in Air Micronesia operations for captains who were new to Air Micronesia operations was compromised when the scheduled first officer called in sick. Nevertheless, the captain's training and experience should have provided for a safe flight. Although an "experienced" first officer would be a plus for a "new" captain, in the case where a captain deviates from established procedures, even a highly experienced first officer may not be able to prevent an accident. Even an "experienced" first officer could be reluctant to correct a captain. In this case, the first officer did advise the captain about being low; however, his similar lack of experience into Yap may have limited his ability to make a more definite evaluation and to recommend proper action. Even though he had recent experience as a B-727 captain and should have been aware of the proper procedure for flying such an approach, his position of first officer could have deterred him from taking more action in expressing his concern about the approach. It is unlikely that even an "experienced" first officer could have prevented the captain from suddenly reducing the thrust to idle. There was insufficient time for the other members of the flightcrew to react and prevent the accident. Therefore, although the unwritten practice of providing an "experienced" first officer for newly trained captains in Air Micronesia operations may provide a higher level of safety, the existing training and experience requirements for air carrier operators should provide for safe operations even for a newly assigned flightcrew.

23

Visual Illusions and Distractions

Another aspect in this case examined by the Safety Board was the possibility that the captain of Flight 614 was confused about the proper glidepath and touchdown point because of visual illusions. The heat waves he reported coming off the trees while on the final approach should not have presented a problem. The other crewmembers did not report such a phenomenon. If the aircraft had been on a proper 3° glidepath, the captain would not have experienced the condition. It certainly should not have caused

sufficient distortion of his view of the runway to cause him to aim short of the 1,000-foot touchdown zone. Furthermore, at the point where he reduced power to idle, such conditions would have no longer existed and, therefore, should not have caused him to believe the runway was made.

A second visual illusion aspect considered by the Safety Board was the possibility that the runway shape, including the undefined edges (see figure 1), may have contributed to the captain's faulty planning of his approach and landing flare. It is apparent that the runway appears wider in the first few hundred feet than its published 100-foot width. Similarly, it appears narrower for the remaining length because of the grass growing through the runway surface. The classic problem of runway width causing illusions pertains to the fact that the pilot uses the apparent convergence angle of the runway edges in perspective to estimate length. Increasing or decreasing the distance between the lines can create illusions of shortening or lengthening of the pilot's perception of the runway length. The wider the runway is from that normally encountered by the pilot, the shorter it appears; but a wider runway also can cause the pilot to think he is lower than his actual height above the runway. In the case of the Yap runway, the width is ill-defined; however, it tends to give the illusion of being longer than its actual length, because the narrower width toward the far end of the runway increases the apparent convergence.

Regardless of the possibilities of illusions because of the Yap runway condition, the Safety Board cannot conclude that this factor contributed to the low, flat approach flown by the captain or to his premature reduction of thrust. The Safety Board believes the pilot was not affected by any of these illusions because he stated that he aimed for about a 300-foot touchdown point rather than the prescribed 1,000-foot point. His aim was actually quite accurate because, if he had not reduced power when he did, he probably would have touched down at or very near his aim point. Therefore, the Safety Board does not believe that visual illusions were a factor in this accident.

The captain engaged in and permitted distracting conversations in the cockpit during the downwind portion of the approach. The taking of pictures and discussion about the use of the camera were contrary to company policy about nonessential conversation in the cockpit below 10,000 feet. This further illustrates the captain's disregard for standard operating procedures. Such a subtle aspect cannot be directly attributed to the cause of this accident; however, it does illustrate an apparent lack of concern about the approach on the part of the captain. The Safety Board supports sterile cockpit procedures which exclude distractions during critical phases of flight.

2.4 Survival Aspects

The crash forces which were transmitted to the occupants during the initial impact and subsequent ground slide were of insufficient magnitude to produce injuries. This is supported by the fact that three passengers were unrestrained by their seatbelts during most of the deceleration and they managed to escape uninjured.

Because the evacuation was completed so quickly, no injuries or fatalities resulted from the fire. Based on statements of the flight attendants, some persons might have been trapped and killed by smoke and fire if the evacuation had taken only a few seconds longer. The loss of more than one-half the exits because of impact damage and fire made the timely evacuation all the more noteworthy. The fact that the aft airstair exit was not opened was nearly catastrophic because one flight attendant and some passengers were almost trapped in that area. It could not be determined if the pneumatic

emergency blow-down system would have forced the exit open; however, the fact that the flight attendant did not know how to actuate the emergency system is a serious concern. Her repeated attempts to open the exit using the normal system delayed her evacuation to a point where she was nearly trapped by the smoke and fire.

CONCLUSIONS

31 Findings

1. The flightcrew was properly certificated and qualified to conduct the flight.
2. The aircraft was properly certificated and maintained in accordance with prescribed procedures.
3. The aircraft touched down on the right main landing gear 13 feet short of the approach end of the landing runway.
4. The right main landing gear separated at initial ground contact.
5. The area of initial touchdown of the right main landing gear tires sloped upward about 4.07°.
6. The combined forces of the excessive sink rate and an unsloping touchdown point exceeded the design strength of the right main landing gear.
7. The captain flew a flat, dragged-in final approach with about a 3° glide slope which required excess thrust.
8. The first and second officers and the mechanic in the cockpit jumpseat were concerned about the approach being low.
9. The captain reduced the throttles to idle 50 feet above the runway elevation, and short of the runway threshold.
10. The landing was the first unsupervised landing at Yap for the captain.
11. The captain had been flying DC-10 aircraft as captain for about 3 1/2 years prior to November 1980.
12. The captain had not landed a B-727 aircraft for 61 days before the date of the accident. He made one landing, at Saipan, on the day of the accident.
13. Fire erupted around the damaged right wing area as the aircraft came to a stop.
14. The crash forces were not sufficient to cause serious impact injuries to the occupants.

15. The evacuation was completed in about 55 seconds.
16. The flight attendants were not aware of how to open the aft airstair exit door using the emergency system.
17. Immediately following the accident investigation, the airline implemented new training techniques to include "hands-on" training on the aft airstair exit emergency opening system.

3.2 Probable Cause

The National Transportation Safety Board determines that the probable cause of this accident was the captain's premature reduction of thrust in combination with flying a shallow approach slope angle to an improper touchdown aim point. These actions resulted in a high rate of descent and a touchdown on upward sloping terrain short of the runway threshold, which generated loads that exceeded the design strength and failed the right landing gear. Contributing to the accident were the captain's lack of recent experience in the B-727 aircraft and a transfer of his DC-10 aircraft landing habits and techniques to the operation of the B-727 aircraft.

4. RECOMMENDATIONS

As a result of this investigation, the National Transportation Safety Board recommended that the Federal Aviation Administration:

Require that air carriers operating applicable Boeing 727 aircraft include emergency procedures for operation of the ventral airstair door in their training programs for cabin crews. (Class I, Urgent Action) (A-81-61)

Issue an Airworthiness Directive on applicable Boeing 727 aircraft to require that the location of the emergency operating control for the ventral airstair door be readily apparent regardless of the position of the access door for the normal system control. (Class I, Urgent Action) (A-81-62)

BY THE NATIONAL TRANSPORTATION SAFETY BOARD

/s/ JAMES B. KING
Chairman

/s/ FRANCIS H. McADAMS
Member

/s/ PATRICIA A. GOLDMAN
Member

/s/ G. H. PATRICK BURSLEY
Member

ELWOOD T. DRIVER, Vice Chairman, did not participate.

April 28, 1981

5. APPENDIXES

APPENDIX A

INVESTIGATION AND PUBLIC HEARING

Investigation

The Safety Board was notified about 1900 e.s.t. on November 20, 1980, that Continental/Air Micronesia Flight 614 had crashed and burned at Yap, Western Caroline Islands. The Safety Board immediately dispatched an investigation team from its Washington, D.C., headquarters with operations, human factors, and airworthiness groups. Working groups for the CVR, FDR, metallurgy, and aircraft performance were formed in Washington, D.C.

Parties to the investigation included representatives of the Federal Aviation Administration, Continental Airlines (Air Micronesia), the Boeing Aircraft Company, and the Air Line Pilots Association

Public Hearing

There was no public hearing held in conjunction with this investigation.

■ •

APPENDIX B

PERSONNEL INFORMATION

Captain M. G. Harris, birthdate February 5, 1931, was hired by Continental Airlines on January 15, 1957. He held an airline transport pilot certificate No. 1344097 with type ratings in DC-10, B-727, B-720, B-707, Learjet, and DC-3 aircraft. He possessed a first-class medical certificate dated June 23, 1980, with the limitation that he possess correcting glasses for near vision while flying. His last line check was on September 13, 1980, in a B-727. He had flown 22:55 hours in the last 30 days, 2 hours of which were in the B-727, and the remainder in a DC-10, as captain. He had flown 64:06 hours in the last 60 days; about 33 hours in the DC-10 and 31 in the B-727. He had flown 106:21 hours in the last 90 days; 33 hours in the B-727 and 73 in the DC-10. He had a total of about 14,000 flying hours of which about 700 hours were in the B-727.

Captain Harris held a DC-10 captain bid prior to November 1, 1980. Because of a reduction-in-force, he was awarded a B-727 captain bid for Air Micronesia operations and attended B-727 requalification training from August 10-22, 1980, in Los Angeles, California. From September 12-20, 1980, Captain Harris flew Air Micronesia line experience training with a check captain. He returned to flying the DC-10 in October. Following is a detailed list of Captain Harris' itinerary for August, September, October, and November 1980:

DC-10 Captain

August 1, 1980	Trip 002, HNL to LAX-DC-10
August 2, 1980	Trip 001, LAX to HNL-DC-10
August 8 and 9, 1980	Called in sick
August 10-22, 1980	LAX B-727 Requalification School and Simulator
August 22, 1980	Returned to HNL
August 31, 1980	Trip 602-HNL to LAX-DC-10
September 1, 1980	Trip 603-LAX to HNL-DC-10
September 12-20, 1980	Air Micronesia Line Experience-B-727-100C 41:37 hours, 20 landings
September 29-30, 1980	Called in sick

DC-10 Captain

October 8, 1980	Trip 001.-HNL to NAN to SYD-DC- 10
October 11, 1980	Trip 002-SYD to PPG to HNL-DC- 10
October 15, 1980	Trip 602-HNL to LAX-DC-10
October 16, 1980	Trip 603-LAX to HNL-DC-10
October 19, 1980	Deadheaded to LAX
October 20-25, 1980	International Ground School-LAX
October 25, 1980	Deadheaded to HNL
October 28, 1980	Trip 600-HNL to LAX-DC-10
October 29, 1980	Trip 607-LAX to HNL-DC-10
November 19, 1980	Deadheaded to Guam

Air Micronesia B-727-100C Captain

November 21, 1980	Trip 611-GUM to SPN-B-727
	Trip 614-SPN to GUM-B-727
	Trip 614-GUM to YAP-B-727 (Accident)

Captain Harris' itinerary for the 8 days he trained with Air Micronesia from September 13-20, 1980, accompanied by Captain Terry Owens was as follows:

<u>Date</u>	<u>Flight No.</u>	<u>Routing</u>	<u>Actual Time</u>	<u>Landing</u>
13 Sep	619	HNL/JON	2:03	Harris
		JON/MAJ	3:03	Harris
		MAJ/KWA	0:47	Harris
14 Sep	619	KWA/PNI	1:33	Harris
		PNI/TKK	1:05	Owens
		TKK/GUM	1:27	Owens
14 Sep	611	GUM/SPN	0:30	Owens
	614	SPN/GUM	0:29	Harris
	614	GUM/YAP	1:23	Owens
15 Sep	614	YAP/ROR	0:51	Harris
	616	ROR/YAP	0:55	Harris
	616	YAP/GUM	1:16	Owens
	616	GUM/SPN	0:33	Harris
	610	SPN/GUM	0:29	Harris
15 Sep	611	GUM/SPN	0:35	Harris
	612	SPN/GUM	0:27	Owens
	612	GUM/TKK	1:32	Harris
16 Sep	612	TKK/PNI	1:14	Harris
	619	PNI/TKK	0:54	Harris
	619	TKK/GUM	1:08	Owens
16 Sep	615	GUM/SPN	0:36	Owens
	614	SPN/NRT	3:14	Harris
17 Sep	620	NRT/SPN	3:09	Harris
	620	SPN/GUM	0:25	Owens
18 Sep	619	GUM/SPN	0:33	Owens
	622	SPN/GUM	0:27	Owens
19 Sep	616	GUM/SPN	0:35	Harris
	626	SPN/GUM	0:27	Harris
20 Sep	612	GUM/TKK	1:37	Harris
		TKK/PNI	1:09	Harris
		PNI/KWA	1:32	Owens
		KWA/MAJ	0:49	Owens
		MAJ/HNL	4:34	Harris

First Officer T. W. Green, birthdate April 27, 1940, was hired by Continental Airlines on August 22, 1966. He held an Airline Transport Pilot Certificate No. 1530276, with type ratings in the DC-10 and B-727 aircraft. He possessed a first-class medical certificate dated October 8, 1980, with no limitations. He had approximately 10,000 flying hours, of which about 5,500 hours were in B-727 aircraft. His last

proficiency check was on July 3, 1980. He had flown 29:15 hours in the last 30 days, **all** in B-727 Air Micronesia operations. He had flown 41:36 hours in the last 60 days, all in the B-727, about 12:21 hours of which were in domestic operations as a B-727 captain. He had flown 100:13 hours in the last 90 days, of which about 69 hours were in domestic operations and the remainder in Air Micronesia operations, **all** in B-727 aircraft.

First Officer Green had held a B-727 captain's bid, based in Houston, Texas, prior to November 1, 1980, at which time his copilot's bid became effective for Air Micronesia operations. He began line training in October for Air Micronesia. During that time he made one supervised landing at Yap (October 20, 1980) and observed one landing by the check captain. He did not fly during November until the day of the accident.

First Officer Green's itinerary for August, September, and October was as follows:

<u>Date</u>	<u>Flight No.</u>	<u>Equipment</u>	<u>Stations</u>	<u>Blk-Time</u>
8-20	216	B-727-200	SAT-IAH-EWR	4+07
8-21	047	B-727-100	EWR-IAH	3+04
8-21	060	B-727-200	IAH-MSY	0+53
8-22	439	B-727-200	MSY-IAH	0+52
8-29	053	B-727-100	IAH-PHX-LAX	3+24
8-29	602	B-727-100	LAX-DEN	1+58
8-30	029	B-727-100	DEN-LAS	1+43
8-30	238	B-727-200	LAS-DEN	1+31
8-30	252	B-727-200	DEN-MAF-SAT	2+11
8-31	216	B-727-200	SAT-IAH-EWR	3+56
9-01	047	B-727-100	EWR-IAH	3+07
9-01	060	B-727-200	IAH-MSY	1+04
9-01	439	B-727-200	MSY-IAH	0+54
9-08	026	B-727-200	SJC-DEN	2+14
9-08	026	B-727-200	DEN-ICT	1+09
9-08	441	B-727-200	ICT-DEN	1+21
9-09	024	B-727-100	DEN-ORD	2+13
9-09	029	B-727-100	ORD-DEN-COS	2+47
9-09	414	B-727-100	COS-DEN	0+37
9-09	045	B-727-200	DEN-SAN	2+10
9-10	464	B-727-100	SAN-DEN	2+04
9-10	774	B-727-200	DEN-IAH	2+07
10-18	619	B-727-100	HNL-JON-MAJ- KWA-PNI-TKK-GUM	9+52
10-19	611	B-727-100	GUM-SPN	0+34
10-19	614	B-727-100	SPN-GUM-YAP-ROR	2+49
10-20	616	B-727-100	ROR-YAP-GUM-SPN	2+35
10-20	610	B-727-100	SPN-GUM	0+32
10-20	611	B-727-100	GUM-SPN	0+35
10-20	61.2	B-727-100	SPN-GUM-TKK-PNI	2+16
10-21	619	B-727-100	PNI-TKK-GUM	2+34
10-22	615	B-727-100	GUM-SPN-NRT	4+03
10-23	620	B-727-100	NRT-SPN-GUM	3+37
10-24	616	B-727-100	GUM-SPN	0+40
10-24	626	B-727-100	SPN-GUM	0+30
10-24	618	B-727-100	GUM-TKK-PNI-KWA MAJ-JON-HNL	10+03

Second Officer J. S. Longo, Jr., birthdate June 14, 1941, was hired by Continental Airlines on March 31, 1969. He held commercial pilot certificate No. 1645830, with airplane single- and multiengine land and instrument ratings. He also held a flight engineer rating No. 1931528, with a rating for the B-727. He possessed a first-class medical certificate dated March 6, 1980, with no limitations.

Second Officer Longo had about 7,000 flying hours, of which about 5,500 hours were in B-727 aircraft. His last proficiency check was on September 25, 1980. He had 34:41 hours in the last 30 days, about 32 hours of which were in Air Micronesia operation as flight engineer. He had 58:16 hours in the last 60 days, about 26 hours of which were in domestic operations as a B-727 copilot. He had flown 131:25 hours in B-727 aircraft during the last 90 days, about 100 hours of which were in domestic operations.

Second Officer Longo held a B-727 first officer's bid in domestic operations until November 1, 1980, at which time the Air Micronesia flight engineer's bid became effective.

■ •

APPENDIX C

AIRCRAFT INFORMATION

The aircraft, a Boeing 727-92C, N18479, Serial No. 19174 was certificated on November 5, 1966, and the Data Sheet Type Certificate No. was A3WE. The aircraft was built as a convertible cargo aircraft. The aircraft can be used in an all-passenger, all-cargo, or cargo/passenger configuration. The aircraft had a maximum taxi weight of 170,000 lbs and a maximum landing gross weight of 142,500 lbs.

The aircraft had been owned and operated first by Air Asia until October 10, 1972, when the aircraft was sold to Pacific Western Limited. Continental Airlines purchased the aircraft on September 3, 1977. The total aircraft hours on September 3, 1977, were 21,866.28 hours. The total aircraft hours on the date of the accident and including the last flight were 30,878.44 hours, and the total number of landings was 20,788.

The aircraft was under the Continental Airlines continuous B-727 maintenance program and the "C" check under this program was accomplished by Continental Airlines at Los Angeles, California, on October 6, 1980, at 30,571.35 hours. After the "C" check maintenance was accomplished, Continental Airlines used the aircraft for domestic service from October 6, 1980, to October 17, 1980. During the period of October 17, 1980, through October 24, 1980, Continental Airlines at Los Angeles, California, prepared the aircraft for Air Micronesia service. The aircraft was flown to Honolulu and placed in scheduled service by Air Micronesia on October 24, 1980. The last time the aircraft was converted to the two cargo-pallet and 78-passenger configuration was in November 17, 1980. A "B1" check was accomplished on November 5, 1980, at Guam by Continental Airlines/Air Micronesia, Inc.; the "B2" check was due after termination of the scheduled flight service of November 21, 1980.

The following airframe, engine, and landing gear inspection data are current up to the date of the accident:

Airframe Inspection

<u>Type of Inspection</u>	<u>Date Accomplished</u>	<u>Airframe Hours</u>
"C" check (14 months or 3,600 hours)	10-06-80	30,571.35
"B1" check (1/6 B check 17 days)	11-05-80	30,764.16

Engine Data

<u>Engines</u>	<u>Mfg. and Model</u>	<u>Serial No.</u>	<u>Total Time Since New</u>
No. 1	P & W JT8D-9A	P66076B	14,789.52
No. 2	P & W JT8D-9A	P665566B ^{1/}	28,866.47
No. 3	P & W JT8D-9A	P665592B	19,355.18

^{1/} The No. 2 engine S/NP665294B was removed after the "C" check was completed and replaced with engine S/NP665566B on October 12, 1980. The reason for the change was to stagger the engine hours.

Engine Heavy Maintenance Information

<u>Engines</u>	<u>Time Since Heavy Maintenance</u>	<u>Aircraft Total Hours</u>	<u>Date Completed</u>
No. 1	307.09	30,571.35	09-29-80
No. 2	256.56	30,621.48	10-12-80
No. 3	307.09	30,571.35	09-29-80

Engine Inspection

<u>Engine</u>	<u>Time Since "B" Check</u>	<u>Aircraft Total Hours</u>	<u>Date Completed</u>
No. 1	114.28	30,764.16	11-05-80
No. 2	256.56	30,621.48	10-12-80
No. 3	307.09	30,571.35	10-01-80

Landing Gear Data

<u>Landing Gear</u>	<u>Time Since Overhaul or Inspection</u>	<u>Total Aircraft Time Completed</u>	<u>Date</u>
Left Main Gear	2,314.01	28,564.43	02-01-80
Left Main Gear Beam	1,206.48	29,671.56	05-29-80
Left Side Strut	2,314.01	18,564.43	02-01-80
Right Main Gear	1,206.48	29,671.56	05-29-80
Right Main Gear Beam	1,206.48	29,671.56	05-29-80
Right Side Strut	1,206.48	29,671.56	05-29-80
Nose Gear	5,827.42	25,051.02	09-03-78
NLG Drag Brace	307.09	30,571.35	10-01-80

Review of the aircraft maintenance records from May 1980 to November 20, 1980, did not reflect any reported hard landings or hard landing inspections accomplished during this period.

The following wheel and tire change information obtained from the maintenance work sheets between October 31, 1980, and November 20, 1980, are as follows:

<u>Date</u>	<u>Wheel and Tire Position</u>
10-31-80	Nose gear tire
11-10-80	No. 3 Main gear tire
11-11-80	Nose gear tire
11-14-80	No. 4 Main gear tire
11-17-80	No. 2 Main gear tire
11-18-80	No. 1 Main gear tire

All aircraft and engine maintenance records from the date of the "C" check on October 6, 1980, until November 20, 1980, were reviewed. The discrepancies noted in these reports were corrected and signed off on these sheets. These included the routine and nonroutine items. There were no deferred items listed or carried over since the last "C" checkdate of October 6, 1980.

The aircraft maintenance log sheet dated November 20, 1980 showed two open items, which were: (1) left hand pack inoperative in takeoff, **all** other flight and ground modes OK; and (2) both **SEL** Call inoperative.

The aircraft maintenance log sheet for the date of the accident, November 21, 1980, was on the aircraft and was not recovered.

APPENDIX D

RUNWAY INFORMATION

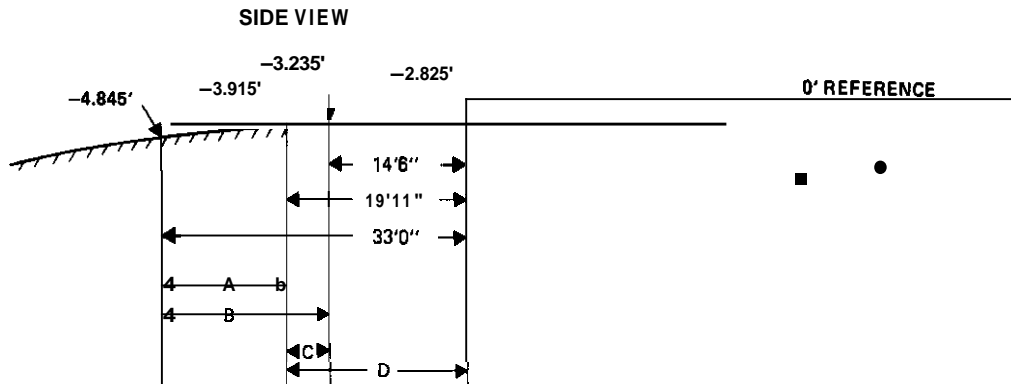
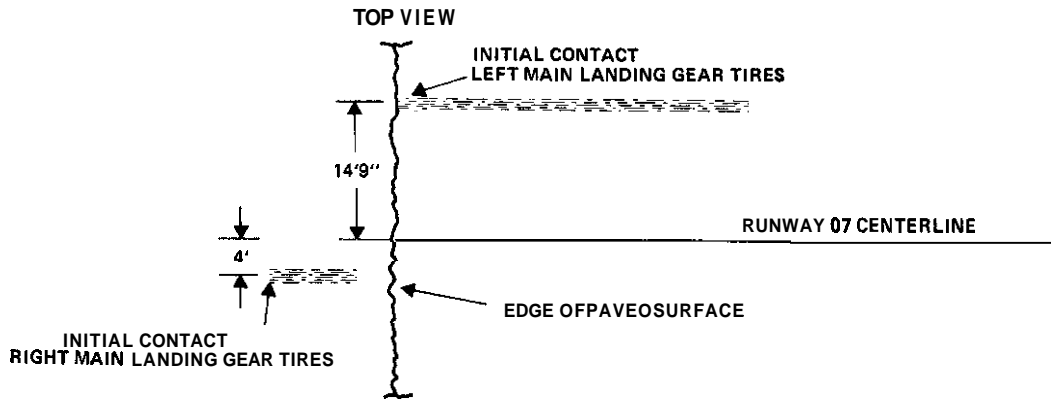

SLOPE ANGLES

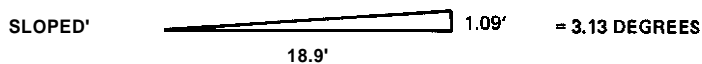
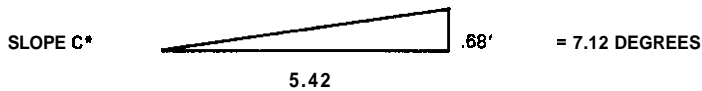
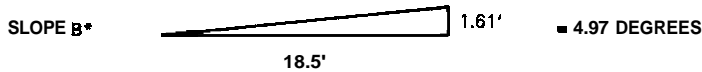
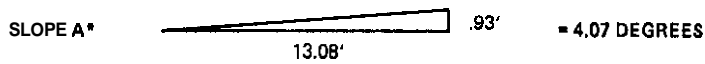

* THESE ARE NOT TO SCALE

APPENDIX E

FLIGHT DATA RECORDER TRACES

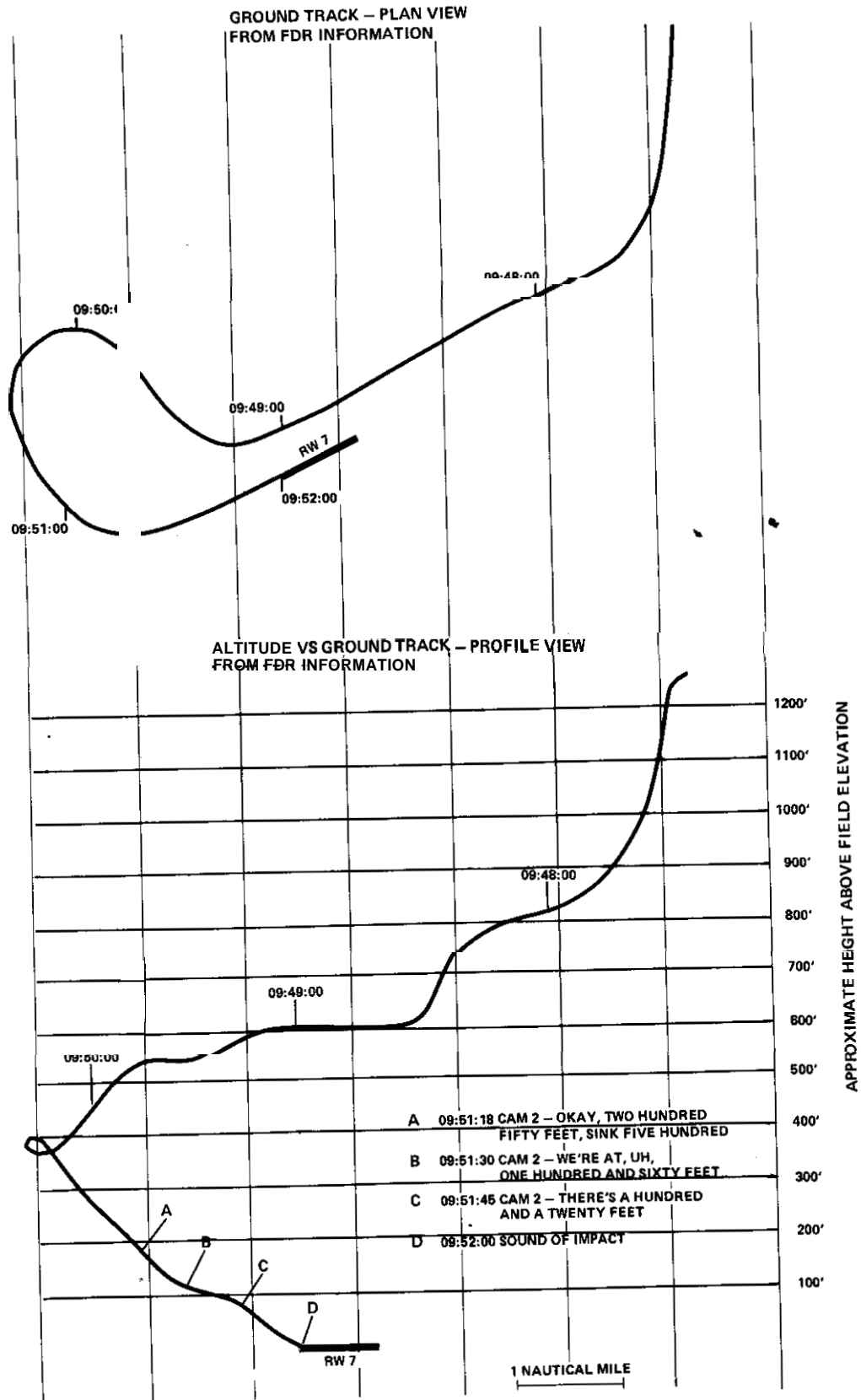

APPENDIX F

COCKPIT VOICE RECORDER TRANSCRIPT

TRANSCRIPT OF A FAIRCHILD MODEL A-100A, S/N 10065, REMOVED FROM CONTINENTAL/
AIR MICRONESIA BOEING 727, WHICH WAS INVOLVED IN AN ACCIDENT AT YAP, WESTERN
CAROLINE ISLANDS ON NOVEMBER 21, 1980

LEGEND

CAM Cockpit area microphone voice or sound source
RDO Radio transmission from accident aircraft
-1 Voice identified as Captain
-2 Voice identified as First Officer
-3 Voice identified as Second Officer
-? Voice unidentified
MECH Voice identified as Mechanic
* Unintelligible word
() Questionable text
(()) Editorial insertial
--- Pause

Note: **A** times are local standard time at Greenwich Mean
 time plus 9 hours.

The transcript is presented as transcribed by the Cockpit Voice
Recorder Group. Comments added in brackets [1 were the result
of review of the tape and transcript by the crew.

AIR-GROUND COMMUNICATIONS

<u>TIME & SOURCE</u>	<u>CONTENT</u>
0932: 42 ROO-3	Ah, Yap radio Continental six fourteen, we're estimating, ah, zero three and do you have the latest weather?
YAP	Continental, ah six fourteen, ah Yap radio, what is your ETA please?
RDO-3	Say again
YAP	What is your ETA?
RDO-3	Zero three
YAP	Roger zero three and, ah, Yap, ah twenty three hundred zee weather two zero hundred scattered, estimated three zero zero thousand broken, visibility ah one two miles, temperature eight four, dew point seven eight, wind direction and speed zero seven zero degrees at five knots, altimeter setting two niner eight five, remarks charlie bravo east and southwest towering cumulus north ((static))
ROO-3	Ah Yap, Continental six fourteen, ah you were cut out after the, ah, altimeter
YAP	Altimeter setting two niner eight five two niner, correction two niner eight five, go ahead
ROO-3	Okay, I've got a two niner eight five and, ah what were the remarks please?
YAP	Ah remarks --- remarks charlie bravo east and southwest towering cumulus north, ah rain showers east, go ahead
0934: 48 RDO-3	Okay, I got it, thank you

INTRA-COCKPIT

0938: 48 CAM-3	Okay, there is some kind of stuff east and southwest towering cu north, rain showers east
0938: 58 CAM-1	Zero seven zero, zero five huh [The captain said he could not verify this was his voice]
CAM-3	I guess you can handle that two thousand scattered, I guess
0939: 02 CAM-3	Five knots down the runway

INTRA-COCKPIT

TIME &
SOURCE

CONTENT

0939: 28 CAM-1	In range when you get a chance
0939: 33 CAM-3	Seatbelt
0939: 34 CAM-2	On
0939: 35 CAM-3	Anti-ice
0939: 39 CAM-2	Electric
0939: 40 CAM-3	Altimeters and airspeed
0939: 42 CAM-2	Cross checked
0939: 43 CAM-3	Reference
0939: 44 CAM-2	One thirty two on the right
0939: 45 CAM-1	Left
0939: 47 CAM-?	* * (pressure)
0939: 52 CAM-3	Shoulder hardness
0939: 53 CAM-2	Comin' on
0939: 53 CAM-1	One twenty seven, five, thirty two on the speed ((simultaneous with "comin' on" above))
0940: 00 MECH	We're going to land coming this way aren't we?
0940: 06 CAM-1	We're too heavy for a tailwind [The captain said this was not his voice]

INTRA-COCKPITTIME &
SOURCECONTENT

0940: 13
CAM-3 I put one thirty eight point three cause that's the maximum legal, we're going to probably be a little over that

0940: 22
CAM-3 We're a hundred forty point six now, which gives us a thousand ninety pounds per knot

0940: 27
CAM-1 Yeah okay

0940: 42
CAM ((Air noise level decreases))

0941: 16
CAM ((Nonpertinent conversation begins))

0942: 37
CAM ((Nonpertinent conversation ends))

0945: 43
MECH * * this is where we leave the flaps down, twenty five degrees, I mean

CAM-? Thank you [Identified by the crew as said by CAM-21

0945: 54
CAM-? Have you got the tower over there okay, Jocko? [Identified by the crew as said by CAM-33

0945: 56
CAM-1 Yeah

0946: 20
CAM-2 mlooking for a golf course now

0946: 25
CAM-2 Plenty of places we can put one in here

0946: 28
CAM-2 Might even get thirty six holes in here --- about a five hundred room hotel

0946: 35
CAM-3 What's that tower do anyway, is that a satellite thing or something?

0946: 38
MECH Nah, that's a Loran

0946: 41
CAM-3 That's a big one for a little bitty island

INTRA-COCKPIT

TIME &
SOURCE

CONTENT

0946: 50
CAM-3 Is that Loran station still active anyway?

0947: 00
CAM ((Airnoise level decreases))

0947: 09
CAM-2 Look how tall that sucker is, one thousand eighty feet

0947:16
CAM-3 * * wind blows from the east here

0947: 19
CAM-2 There's that old abandoned Jap air field over there

0947: 22
CAM-1 Right over there?

CAM-2 Yeah, right over there

0947: 27
CAM-3 Yeah that's what I thought first time we came in

MECH * * field

0947: 30
CAM-1 Two

0947: 31
CAM ((Sound of two clicks))

0947: 38
CAM-3 This doppler shows fifteen miles to go and the other one shows fifteen miles to go

0947:43
CAM-2 Where is the big motel? You ever been here?

0947: 48
MECH Yeah, right down in front of you right here

0947: 50
CAM-2 Right down in here

0947: 51
MECH Yeah --- two of them * *

0947: 57
CAM ((Sound of chime))

INTRA-COCKPIT

<u>TIME & SOURCE</u>	<u>CONTENT</u>
0948: 02 CAM	((Sound of single click)) ((Sound of trim motor))
0948: 05 CAM-1	Flaps fifteen
CAM	((Sound of trim motor))
0948: 09 CAM	((Sound of gear horn))
0948: 19 CAM-1	* * about here [The captain said he could not verify this was his voice]
0948: 22 CAM	((Sound of trim motor))
0948: 29 CAM	((Sound of trim motor))
0948: 34 CAM-1	Twenty five
0948: 37 CAM-2	Twenty five, that's a plane! ["that's a plane!" is identified by the first officer as, "that's the place," possibly said by the mechanic]
0948: 39 CAM	((Sound of trim motor))
MECH	That's it
0948: 43 CAM-3	Where's the wind sock on this thing? Oh!
0948: 50 MECH	More like a direct crosswind than * * [Identified by the crew as said by CAM-31]
0948: 56 CAM-3	Okay, just so you know we weigh a hundred forty point five
0949: 00 CAM	((Sound of trim motor))
0949: 01 CAM-3	About twenty two hundred over max gross
0949: 03 CAM	((Sound of trim motor))

INTRA-COCKPIT

TIME &
SOURCE

CONTENT

0949: 24 CAM-1	Gear down, landing check
CAM	((Sound of gear handle and gear extension))
0949: 29 CAM-1	Thirty with the green
0949: 31 CAM-2	Thirty with the green * *
0949: 36 CAM-2	Down and three green
CAM-3	No smoke
CAM-2	On
0949:40 CAM-3	Beacon
CAM	((Sound of trim motor))
0949: 44 CAM-2	Gravel
CAM-3	Anti-skid
CAM	((Sound of trim motor))
0949:47 CAM-2	Capped five releases
CAM-3	Speed brake
0949:49 CAM-2	Full forward
CAM	((Sound of trim motor))
CAM-3	Flaps
0949: 52 CAM-2	Thirty, thirty landing
0949: 59 CAM-3	Okay we're all set up
0950:02 CAM-3	Depressurized!

INTRA-COCKPITTIME &
SOURCECONTENT

0950: 03
CAM-1 Get a couple pictures of that runway ~~w~~ ya? **A**
you have to do is, that way, hit **it** and click **it**

0950: 14
MECH It's automatic? * * [Identified by the crew as said
by CAM-31

0950: 15
CAM-1 Yeah everything's automatic, just take the picture like
that

MECH Yeah I just wanted to know **if** it's automatic [Identified
by the crew as said by CAM-31

0950: 24
CAM-1 Yeah --- that's the only kind I can operate

0950: 33
CAM ((Sound of **trim** motor)) ■ •

0951:07
CAM ((Sound of **trim** motor))

0951:13
MECH Good one in the turn [Identified by the crew as said by
CAM-31

0951:18
CAM-2 Okay, two hundred and fifty feet, sink five hundred

0951:24
CAM-2 Tad low

0951:30
CAM-2 We're at, uh, one hundred and sixty feet

0951:34
CAM-2 Sink of three hundred

0951:45
CAM-2 There's a hundred and a twenty feet

0951:55
CAM-2 Fifty feet

0951:55
CAM ((Decreasing pitch change to engine noise level, continues
to time of impact))

0951:51
CAM ((Sound of click))

INTRA-COCKPIT

TIME &
SOURCE

CONTENT

0952: 00 CAM	((Sound of impact))
CAM	((Gear warning horn simultaneous with impact))
0952:07	((End of recording))

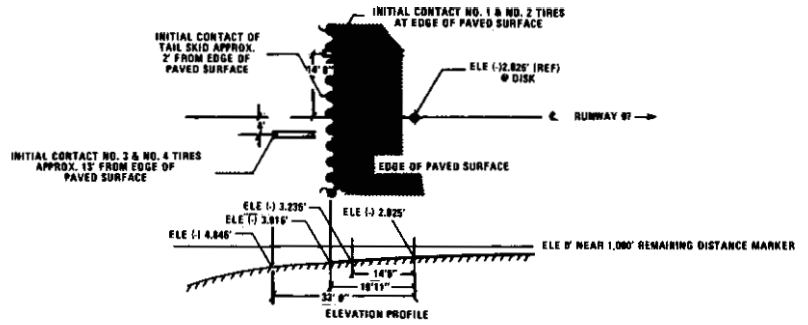

DETAIL @ END OF RUNWAY 07

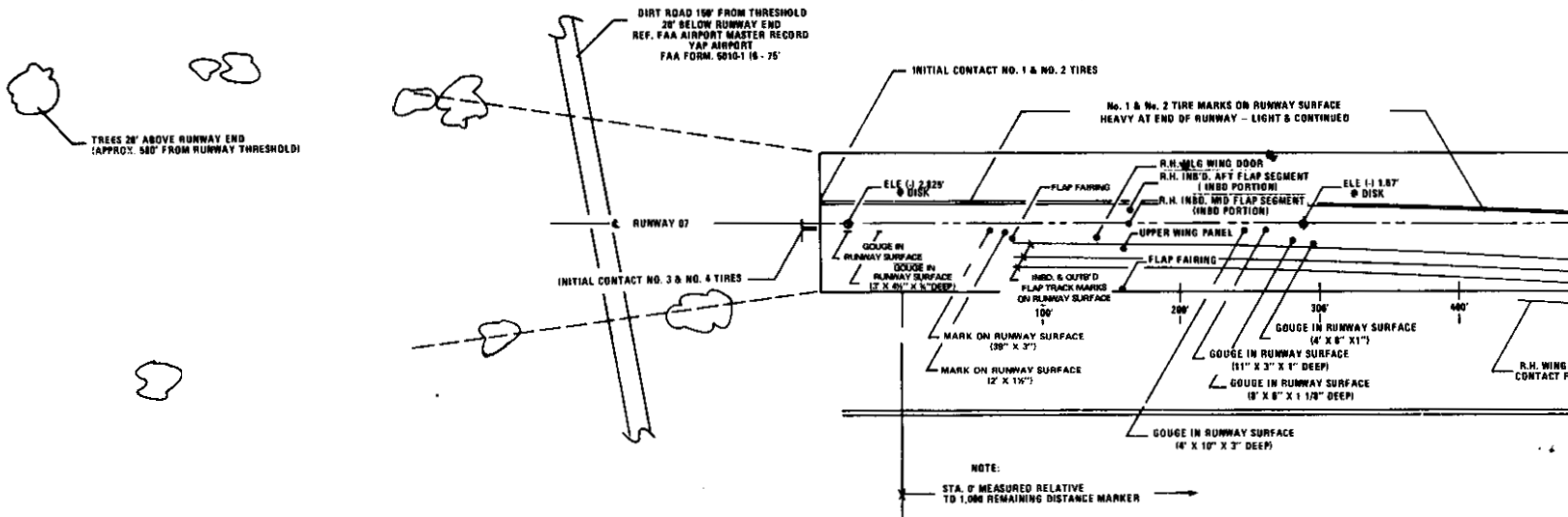

NO. 2 TIRES
ON RUNWAY SURFACE
02.825' (REF)
Ø DISK

RUNWAY 07

ELE 0' NEAR 1,000' REMAINING DISTANCE MARKER

